



INSTALLATION INSTRUCTIONS

SNYPER TUBULAR FENDERS

APPLICATION:

2007-2017 Jeep Wrangler JK

PART NUMBER:

62-1005, 62-1015

ITEM	QUANTITY	DESCRIPTION	TOOLS NEEDED
1,2	2	FRONT FENDERS, DRIVER (1) AND PASSENGER (2) (P/N: 62-1005)	13MM SOCKET
3	2	TURN SIGNAL AMBER LIGHT	13MM WRENCH
4	1	10FT BLACK WELTING	10 MM SOCKET
5	2	TURN SIGNAL BRACKET	10MM WRENCH
6,7	2	SPACER PLATE, DRIVER (6) AND PASSENGER (7)	25/64" DRILL BIT
8	16	M6 HEX SOCKET BUTTON HEAD SCREW (BLACK ZINC)	DRILL
9	20	M6 SERRATED FLANGE NUT (BLACK ZINC)	ALLEN WRENCH
10	4	SHORT M6 HEX HEAD CAP SCREW (BLACK ZINC)	RATCHET
11	2	M8 HEX HEAD CAP SCREW (BLACK ZINC)	TORQUE WRENCH
12	2	M8 SERRATED FLANGE NUT (BLACK ZINC)	
13	2	M8 FLAT WASHER (BLACK ZINC)	
14	2	LONG M6 HEX HEAD CAP SCREW (BLACK ZINC)	
15	18	M6 SPLIT LOCK WASHER (BLACK ZINC)	
16	22	M6 FLAT WASHER (BLACK ZINC)	
17	4	M4 PHILLIPS PAN HEAD SCREW (BLACK ZINC)	
18	4	M4 SPLIT LOCK WASHER (BLACK ZINC)	
19	4	M4 HEX NUT (BLACK ZINC)	
20	1	DOUBLE SIDED TAPE	
21,22	2	REAR FENDERS, DRIVER (21) AND PASSENGER (22) (P/N: 62-1015)	
23	1	11FT BLACK WELTING	
24	16	M6 HEX SOCKET BUTTON HEAD SCREW (BLACK ZINC)	
25	4	M6 SERRATED FLANGE NUT (BLACK ZINC)	
26	16	M6 FLAT WASHER (BLACK ZINC)	
27	12	M6 SPLINED RIV-CERT (YELLOW ZINC)	
28	1	M6 HEX HEAD CAP SCREW (YELLOW ZINC)	
29	1	M6 RIV-CERT HAND INSTALL TOOL	
30	1	DOUBLE SIDED TAPE	
31	16	M6 SPLIT LOCK WASHER (BLACK ZINC)	

ANTI-SEIZE LUBRICANT MUST BE USED ON ALL STAINLESS STEEL FASTENERS TO PREVENT THREAD DAMAGE AND GALLING

NOTE: Front Fenders (62-1005) are sold separate from Rear Fenders (62-1015).

CARE INSTRUCTIONS

- REGULAR WAXING IS RECOMMENDED. DO NOT USE ANY TYPE OF POLISH OR WAX THAT MAY CONTAIN ABRASIVES.
- STAINLESS STEEL PRODUCTS CAN BE CLEANED WITH MILD SOAP AND WATER. STAINLESS STEEL POLISH SHOULD BE USED TO POLISH SMALL SCRATCHES.
- GLOSS BLACK FINISHES SHOULD BE CLEANED WITH MILD SOAP AND WATER.

WESTIN Westin Automotive Products, Inc.
320 W. Covina Blvd
San Dimas, Ca. 91773

Thank you for choosing Westin products
for additional installation assistance please call
Customer Service (800) 793-7846

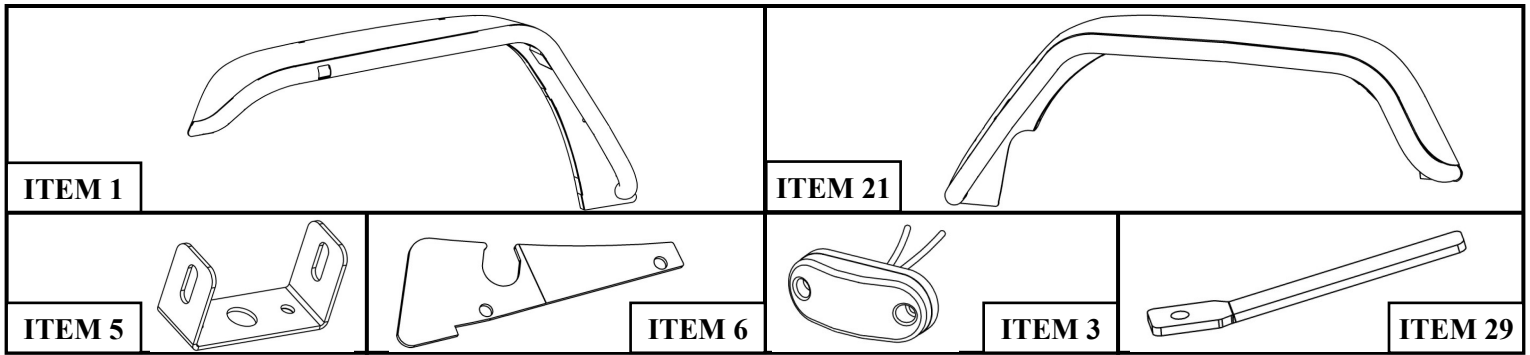

PROCEDURE

1. Remove contents from box, verify if all parts listed are present and free from damage. Carefully read and understand all instructions before attempting installation.
Failure to identify damage before installation could lead to a rejection of any claim.

Front Fender Installation:

2. Starting on either side. Reach inside the front factory fender flare and disconnect the outer signal wiring harness.
3. Along the inner fender remove the factory M10 bolts. Once the inner fender plastic is loose, carefully pull the outer fender flare off.
4. Remove any plastic clips that are still attached to the vehicle. **Note:** Clean fender area if needed.
5. Locate (1) Front Fender (Item 1/2), Black Welting (Item 4) and Double Sided Tape (Item 20). Along the outer front fender use the double sided tape to stick the black welting onto the front fender. See **Figure 1**. **Note:** Trim welting to make sure that holes along the fender are not covered. The welting will require triangles to be cut into the flat portion to allow it to flex around the corners.
6. Locate (1) Turn Signal Bracket and (1) Turn Signal Amber Light and secure together using provided M4 hardware (Items 17 - 19). See **Figure 2**.
7. Align Front Fender with the vehicles fender area and loosely secure using the provided M6 and M8 hardware. Refer to **Figure 3**.
8. Align and adjust Front Fender as needed and then tighten hardware: M8 to 17 ft-lbs and M6 to 10 ft-lbs.
9. Repeat **Steps 2 - 8** for opposite side.
10. On both front fenders connect the Turn Signal Amber Light with the vehicle wire harness. Solder or use butt connectors to connect wires. **Note:** White wire is ground and Black wire is positive.
11. Trim the factory inner fender and tuck it behind the welded lip on the Westin Fenders. Use factory hardware to secure.

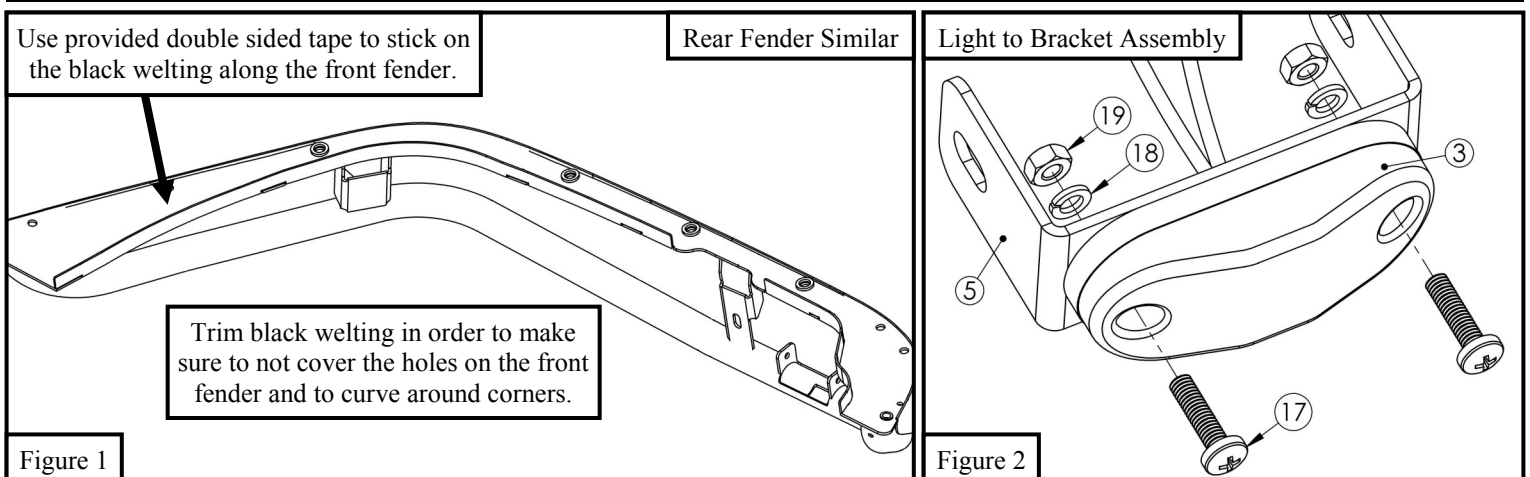

Driver Side Shown

Note: For the Turn Signal Amber Light (Item 3) the White wire is ground and the Black wire is positive.

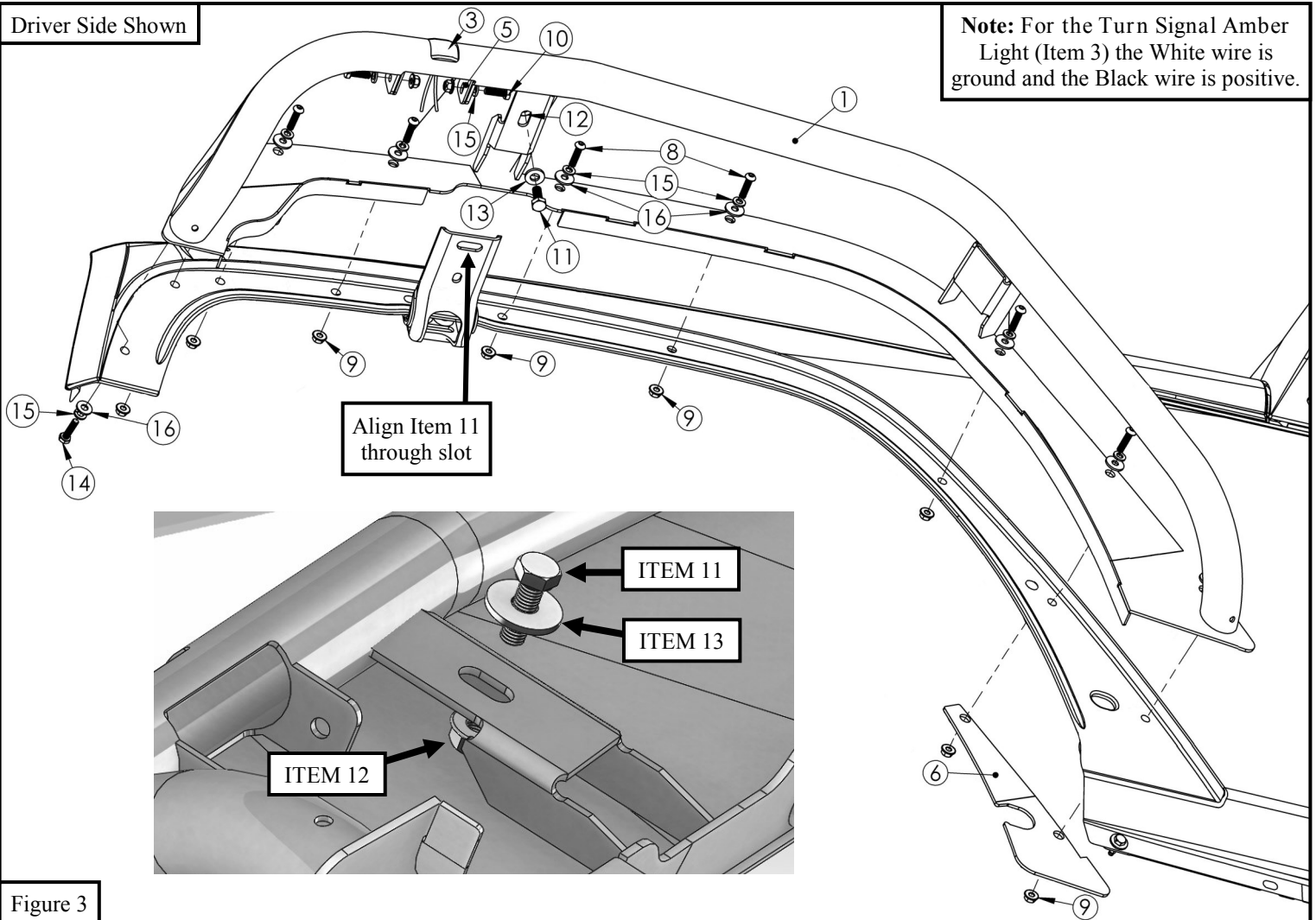

Figure 3

Rear Fender Installation:

2. Starting on either side of vehicle. Remove plastic clips along the inner factory fender. Once all of the plastic clips are removed, carefully pull the factory fender flare off.
3. Remove any plastic clips that are still attached to the vehicle. **Note:** Clean fender area if needed.
4. Drill the pre-existing holes along the vehicle fender area to prepare them for riv-certs. Use a 25/64" drill bit. See **Figure 4**. **Note:** Holes accessible from the rear do not need to be drilled.
5. Locate the provided M6 Riv-Cert Hand Install Tool (Item 29), (6) M6 Riv-Certs (Item 27), and (1) M6 hex head cap screw (Item 28). Install the M6 Riv-Certs onto the vehicle fender in the previously drilled factory holes using the M6 Riv-Cert Hand Install Tool and M6 hex head cap screw. Refer to **Figure 5**. **Note:** Do not attempt to use the button head bolts for this; they may strip.
6. Locate (1) Rear Fender (Item 21/22), Black Welting (Item 23) and Double Sided Tape (Item 30). Along the outer rear fender use the double sided tape to stick the black welting. Refer to **Figure 1**. **Note:** Trim welting to make sure that holes along the fender are not covered. The welting will require triangles to be cut into the flat portion to allow it to flex around the corners.
7. Align Rear Fender with the vehicles fender area and loosely secure using the provided M6 hardware. Refer to **Figure 6**.
8. Align and adjust Rear Fender as needed and then tighten hardware: M6 to 12 ft-lbs.
9. Repeat **Steps 2 - 8** for opposite side.

Drill circled factory holes to enlarge.

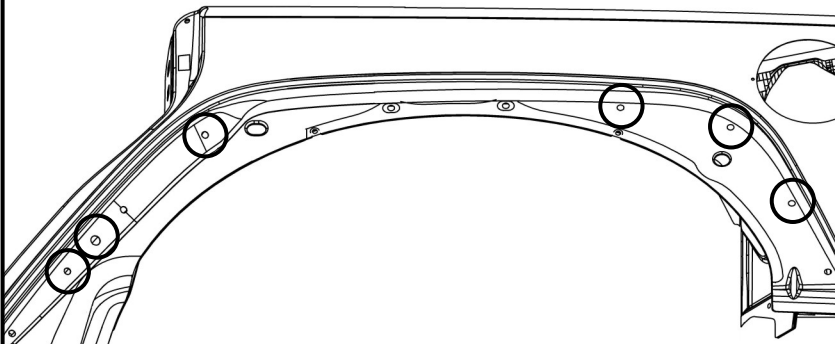
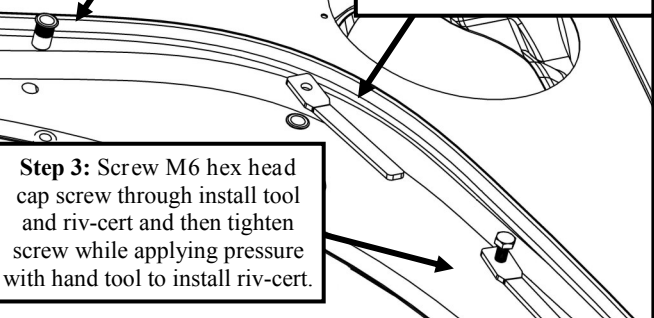

Figure 4

Drill pre-existing factory holes using a 25/64" drill bit on the vehicle fender area.

Step 1: Insert M6 Riv-Cert into drilled hole.

Step 2: Apply pressure onto riv-cert using provided M6 riv-cert hand install tool.



Step 3: Screw M6 hex head cap screw through install tool and riv-cert and then tighten screw while applying pressure with hand tool to install riv-cert.

Repeat (3) Steps for every drilled hole from Figure 4.

Figure 5

Rear Driver Side Shown

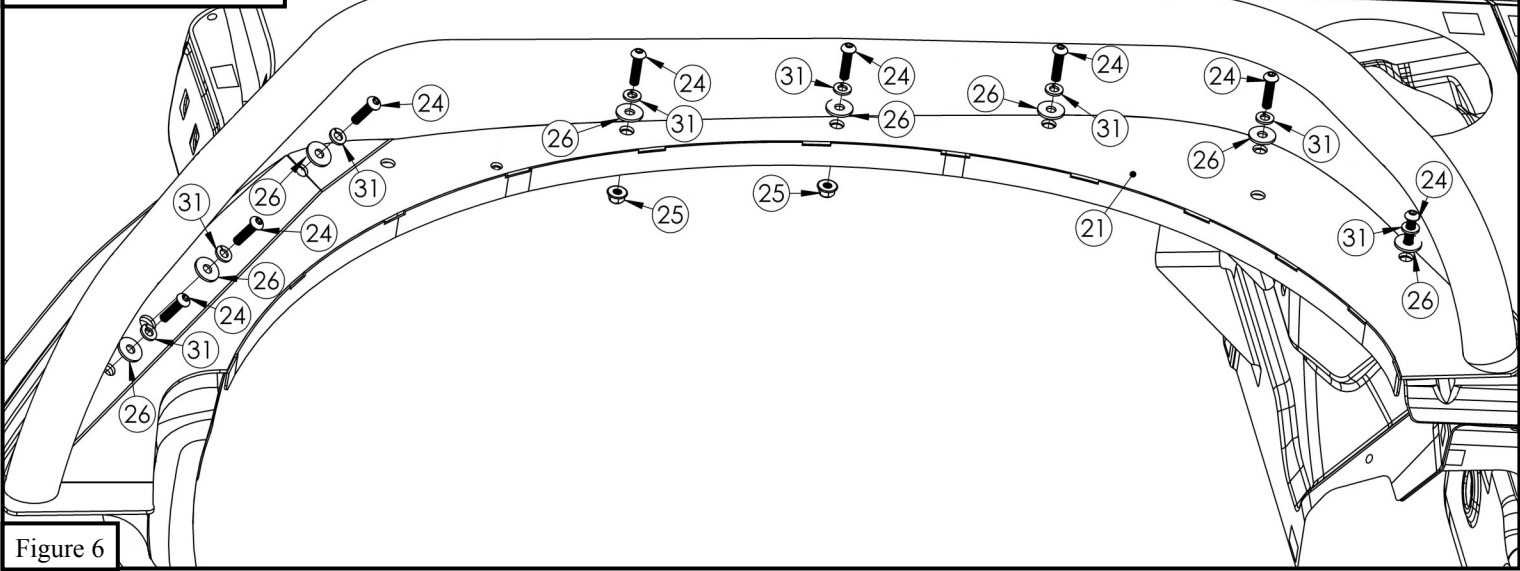

Figure 6

INSTALLATION COMPLETE



WESTIN Westin Automotive Products, Inc.
320 W. Covina Blvd
San Dimas, Ca. 91773

Thank you for choosing Westin products
for additional installation assistance please call
Customer Service (800) 793-7846
www.westinautomotive.com
DATE: 7/31/17



WARNING



Failure to follow these instructions could lead to death, personal injury, and / or property damage.

FASTENERS:

All Westin supplied fasteners must be utilized and installed in accordance with the installation instructions and apply torque to the specifications as defined. **DOUBLE CHECK ALL FASTENERS BEFORE INITIAL USE, AND PERIODICALLY IN THE FUTURE TO ENSURE PROPER FUNCTION AND SAFETY.**

DRILLING:

Most Westin products do not require drilling for installation. If drilling is defined as required, use caution when drilling a vehicle. **FAILURE TO REVIEW AN AREA TO BE DRILLED MAY RESULT IN PERSONAL INJURY AND/OR INJURY TO OTHERS AS WELL AS VEHICLE DAMAGE.**

EYE PROTECTION:

ALWAYS WEAR SAFETY GLASSES OR GOGGLES DURING THE INSTALLATION PROCESS TO AVOID PERSONAL INJURY.

MAXIMUM TOWING/CARRYING CAPACITY:

The Westin Receiver Hitches will have a visible tow rating label affixed directly on the product. User should never exceed the vehicle manufacturers maximum tow and weight rating regardless of the capacity of the hitch. **FAILURE TO FOLLOW THESE GUIDELINES WILL VOID THE WESTIN WARRANTY AND MAY RESULT IN PERSONAL INJURY AND/OR INJURY TO OTHERS AS WELL AS VEHICLE DAMAGE.**